

C60 Assembly Instructions

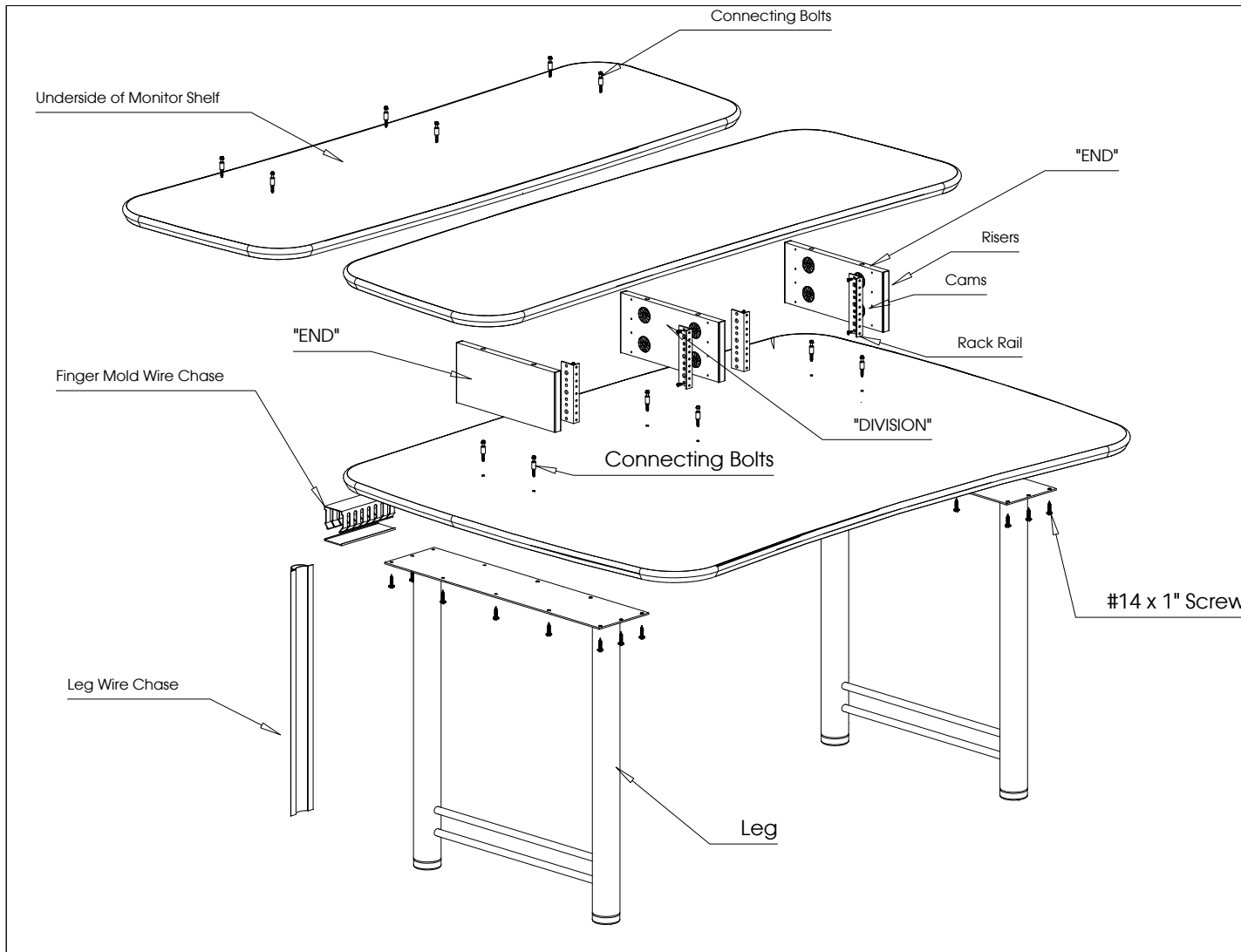

1. Attach the 2 desk legs : Place the desk face down on a non-abrasive surface. Position the legs over the pre-drilled 5mm holes. Attach using (8) #14x1" black screws.
2. Stand the desk up on its legs. Attach the Connecting Bolts to the desk top and underside of the monitor bridge using a #3 phillips head or flat blade screw driver.
3. Attach the risers to the desk top: Attach the Rack Rail to the Risers using the included #10x1/2" screws Place risers over the connecting bolts. Using the included 6mm allen wrench, tighten the cams.
4. Place the monitor bridge on the risers. Tighten the cams, again using the 6mm allen wrench.
6. Attach the wire chase to the underside of the desk where desired using the 3/4" #8-10 screws. There are no pre-drilled holes, but the screws are self-tapping.
7. Attach the Vertical Wire Chase to one of the legs. Remove adhesive strips and place where desired.

If you have any problems or questions please call us at 800.356.6224

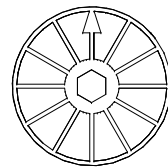

Cam



Connecting Bolt
(12)

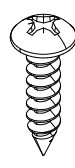

#14 Screw
(16)

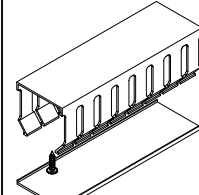

Finger Mold Wire Chase (2)
#8-10 x 3/4" Self Tapping
Screw (6) (3 per section)

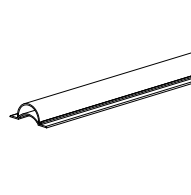

Leg Wire Chase (1)

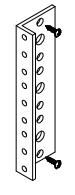

Rack Rail (4)
#10 x 1/2"
screw (8)